

DIST.

A TERMINI DI LEGGE E' VIETATA LA RIPRODUZIONE O LA NOTIFICAZIONE DI QUESTO DISEGNO A TERZI SENZA AUTORIZZAZIONE

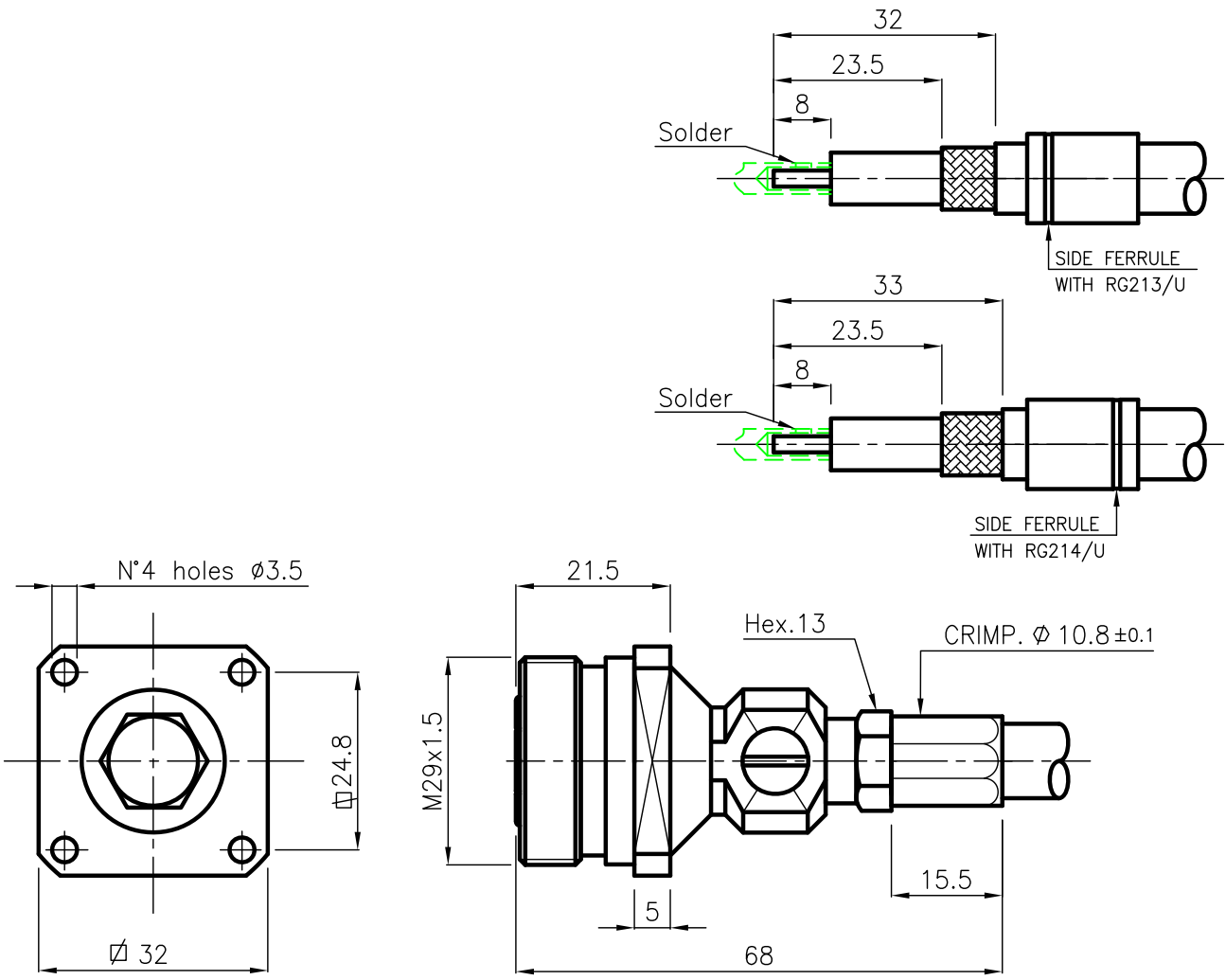

SPECIFICATIONS

Mating and dimensions as per CECC 22190

MATERIALS AND FINISH

Body	Brass	White Bronze
Center Contact	Spring Bronze	Ag 5µ min.
Outer Contact	Brass	Ag 5µ min.
Insulator	PTFE	
Crimping ferrules	Soft copper	Ni 3µ min.

FOR CABLE : RG 214/U-RG213

DENOMINAZIONE		
50 Ohm - 7/16 SERIES CONNECTOR SOLDER CRIMP		
SCALA	1 : 1	CONTR. Cucchi I
FILE	RPD57001C-1	APPROV. A.Q. Cucchi M.
DATA	08.03.04	DIS. Torti E.



N° CODICE
RPD.57.001

MOD. 101