

DIST.

A TERMINI DI LEGGE E' VIETATA LA RIPRODUZIONE O LA NOTIFICAZIONE DI QUESTO DISEGNO A TERZI SENZA AUTORIZZAZIONE

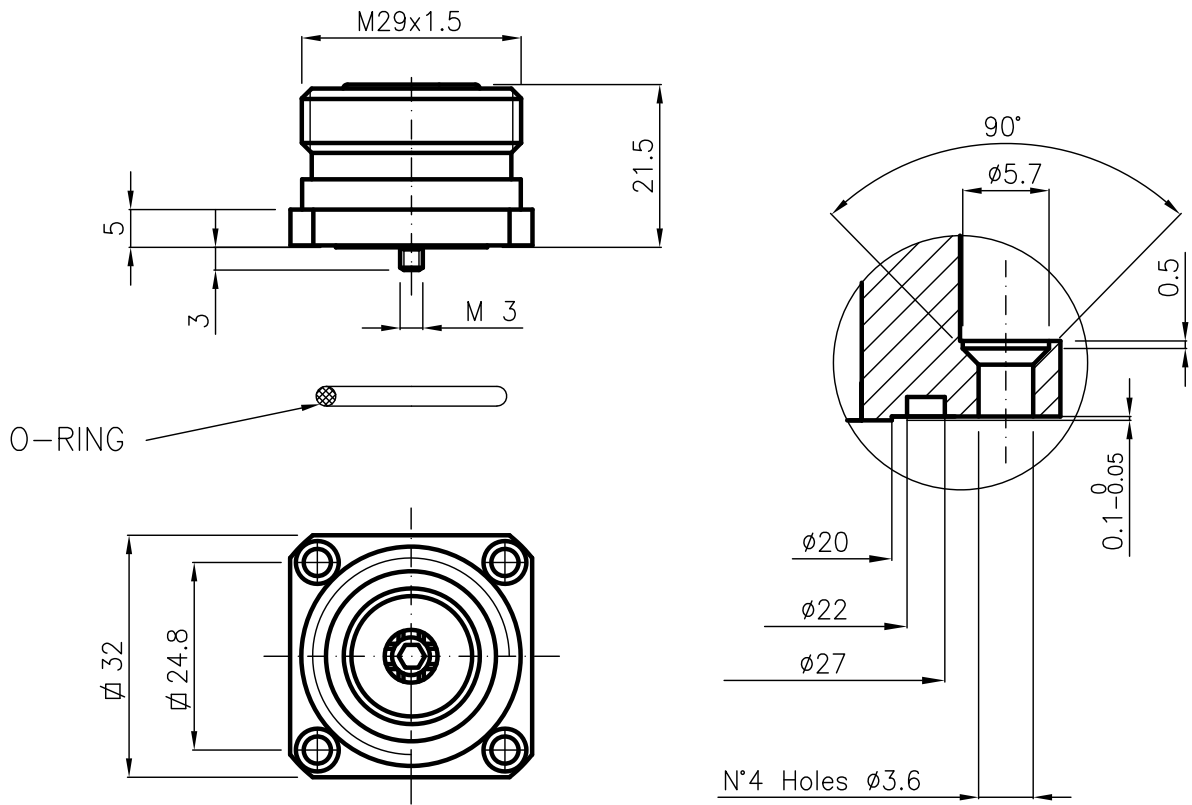

Mating and dimensions as per CECC 22190

ELECTRICAL SPECIFICATIONS

FREQUENCY RANGE	V.S.W.R.
DC÷3 GHz	≤ 1.05
3÷6 GHz	≤ 1.10

MATERIALS AND FINISH

Body	Brass	White Bronze
Insulator	PTFE	
Spring center contact	Spring Bronze	Ag 5 μ min.
Gasket	Silicone rubber	

MOD. 101

			DENOMINAZIONE					
03	Aronica R.	17.09.07	50 Ohm 7/16					
02	Lorenzon I.	11.04.06	SOCKET STRAIGHT PANEL IP68			N° CODICE		
01	Aronica R.	22.01.03	SCALA	1:1	CONTR. CUCCHI I.			DATA
/	SSUED	27.11.03	FILE	RPD04023C-3	APPROV. CUCCHI M.	DIS.	Cucchi I	
REV.	N° MOD.	DATA						RPD.04.023