

DIST.

A TERMINI DI LEGGE E' VIETATA LA RIPRODUZIONE O LA NOTIFICAZIONE DI QUESTO DISEGNO A TERZI SENZA AUTORIZZAZIONE

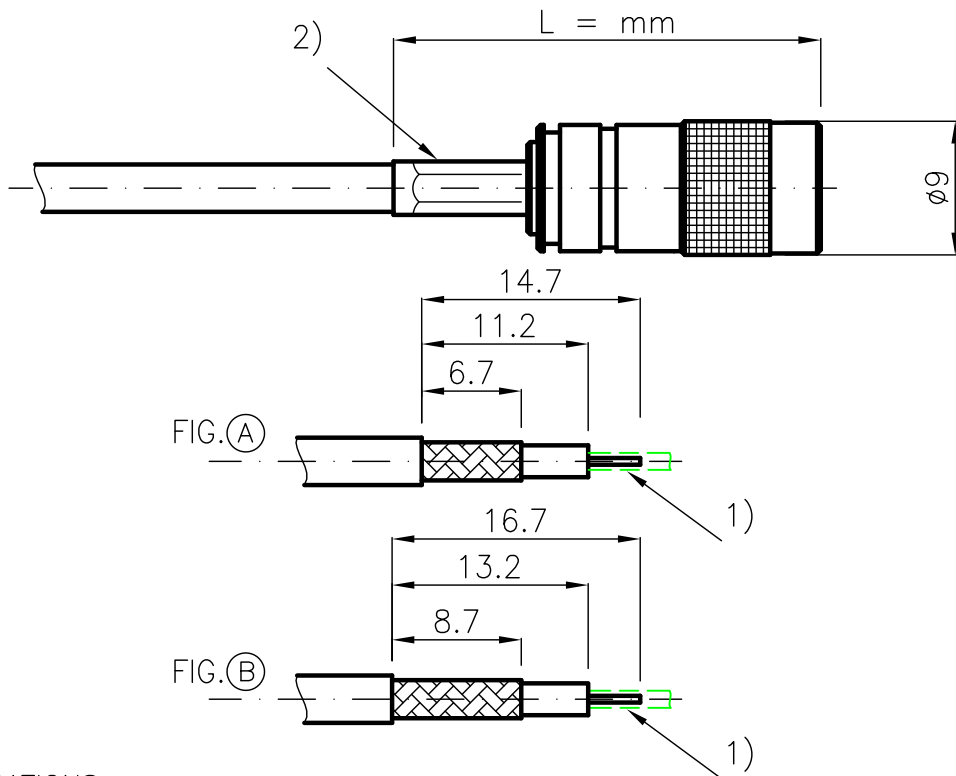

SPECIFICATIONS

Mating and dimensions

as per BS 9210 TYPE 43

CODE	CABLE	L = mm	FIG.	¹ CRIMP. \square CONTACT	² CRIMP. ϕ EXTERNAL
USD.50.001	ST 212	29	A	1.2	3.8
USD.50.002	RG59 B/U	32	B	1.2	6.8
USD.50.003	BT 3002	29	A	1.2	4.06
USD.50.004	RG179 B/U-RG187 B/U	29	A	1.2	3.2
USD.50.005	ST 214	32	B	1.2	6.8
USD.50.006	FLEX 2/75	29	A	1.2	3.25
USD.50.007	FLEX 3/75	29	A	1.2	4.52
USD.50.008	FLEX 5/75	29	A	1.2	5.41
USD.50.009	FLEX 6/75	32	B	1.2	6.48
USD.50.010	BT 2003	32	B	1.2	6.8
USD.50.011	ST 121-RA 7000	29	A	1.2	5.41
USD.50.012	2,5C-2V	32	B	1.2	5.41
USD.50.013	TCE2HH2-1(0,53/2,45)M	32	A	1.2	5.41
USD.50.014	AMPHENOL SAT. ϕ 3.8 L910/39 ; 1AC00510001	32	A	1.2	5.41
USD.50.015	ST 779	32	A	1.2	4.52
USD.50.016	0.30/1.95/3.55	29	A	1.2	4.06
USD.50.017	RD179	29	A	1.2	3.8

USING CRIMPING TOOLS CMC.702/XX

DENOMINAZIONE			75 Ohm - CONNECTORS SERIES BT43		
STRAIGHT SOCKET WITH CRIMP ATTACHMENT					
01	TORTI E.	27.01.03	SCALA	2 : 1	CONTR. CUCCHI I.
/	ISSUED	25.05.00	FILE	USD50XXC-1	DATA
REV.	N° MOD.	DATA	APPROV. CUCCHI M. A.Q.	DIS. Torti E.	

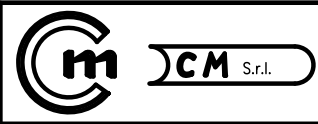

N° CODICE
USD.50.XXX

MOD. 101