

DIST.

A TERMINI DI LEGGE E' VIETATA LA RIPRODUZIONE O LA NOTIFICAZIONE DI QUESTO DISEGNO A TERZI SENZA AUTORIZZAZIONE

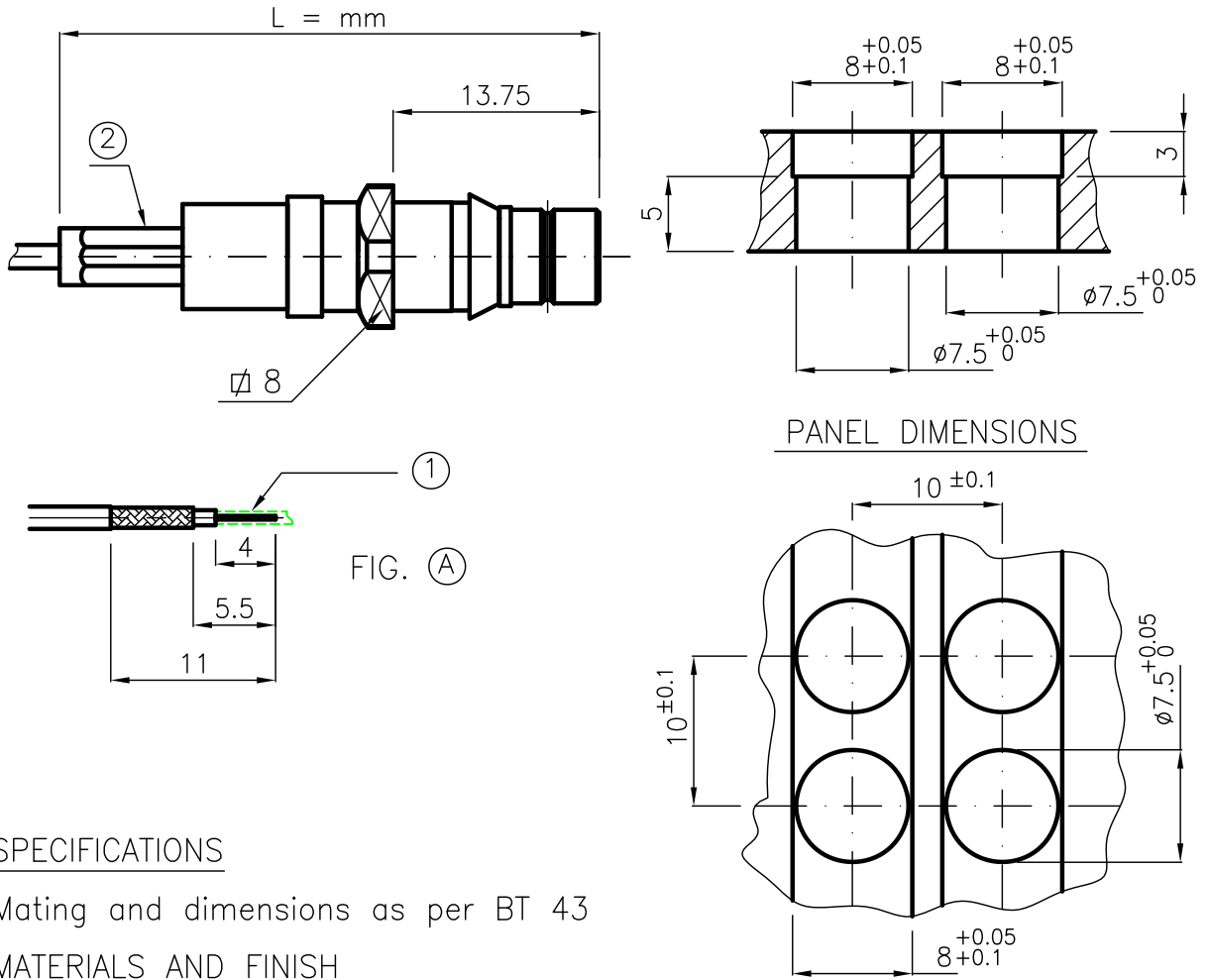

SPECIFICATIONS

Mating and dimensions as per BT 43

MATERIALS AND FINISH

Body	Brass	Au
Plug inner contact	Brass	Au
Insulator	PTFE	
Other metal parts	Brass	Ni
Crimping ferrules	Soft Brass	Ni

CODE	CABLE	L=mm	FIG.	① CRIMP CONTACT	② CRIMP FERRULE
UPD.91.001	72480 - 2870 - 1020 NORTEL	36	A	1.2	3.25
UPD.91.002	RG 179B/U ; RG 187B/U	36	A	1.2	3.25
UPD.91.003	ST 212/1 ; ST212/2 R1-T 2,0 LI -75K	36	A	1.2	3.8

USE TO CRIMP : CMC.702/21

DENOMINAZIONE		BT 43 SERIES COAXIAL CONNECTOR	
		75 Ohm STRAIGHT PLUG - 2 PIECES PARTS	
SCALA	2:1	CONTR. CUCCHI I.	DATA 13.11.02
FILE	UPD91XXC	APPROV. CUCCHI M.	DIS. ARONICA R.

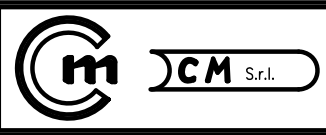

N° CODICE  
**UPD.91.XX1**

MOD. 101