

DIST.

A TERMINI DI LEGGE E' VIETATA LA RIPRODUZIONE O LA NOTIFICAZIONE DI QUESTO DISEGNO A TERZI SENZA AUTORIZZAZIONE

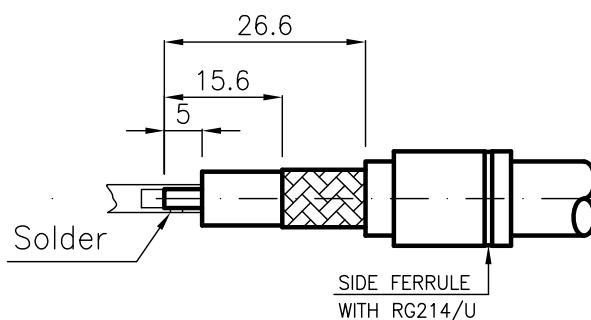
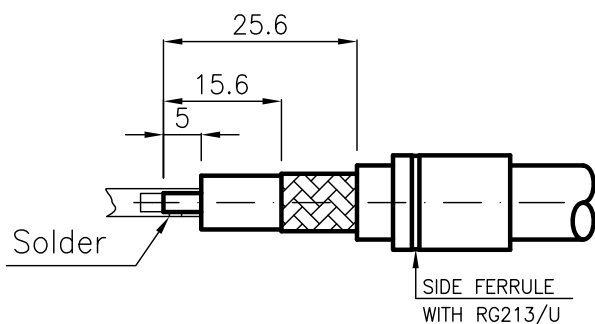
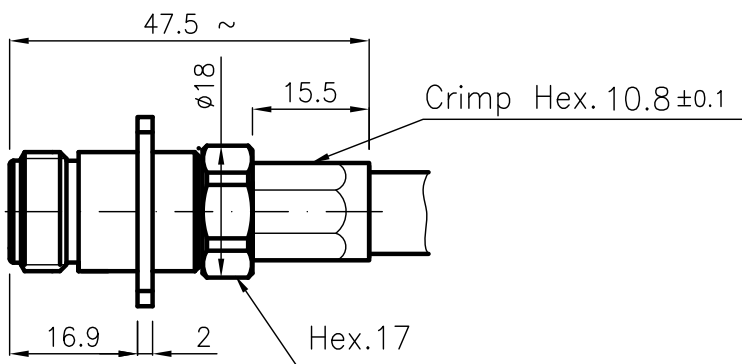
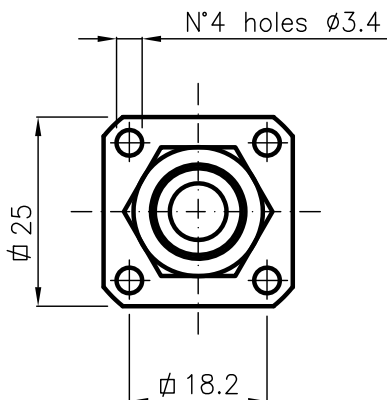

SPECIFICATIONS

Monting and dimensions

as per CECC 22210

MATERIALS AND FINISH

Body	Brass	Ni
Center contact	Beryllium copper	Au
Insulator	PTFE	PTFE
Crimp Ferrules	Soft copper	White Bronze
Other metals parts	Brass	White Bronze

FOR CABLE : RG214/U-RG213/U

MOD. 101

			DENOMINAZIONE			
			50 Ohm-SERIES N CONNECTOR STRAIGHT SOCKET SOLDER CRIMP			
01	ARONICA R.	28.10.11	SCALA	2:1	CONTR. CUCCHI I.	DATA
/	ISSUED	08.03.04	FILE	NPD53004C-1	APPROV. CUCCHI M.	08.03.04
REV.	N° MOD.	DATA			DIS. TORTI E.	N° CODICE
						<b>NPD.53.004</b>