

DIST.

A TERMINI DI LEGGE E' VIETATA LA RIPRODUZIONE O LA NOTIFICAZIONE DI QUESTO DISEGNO A TERZI SENZA AUTORIZZAZIONE

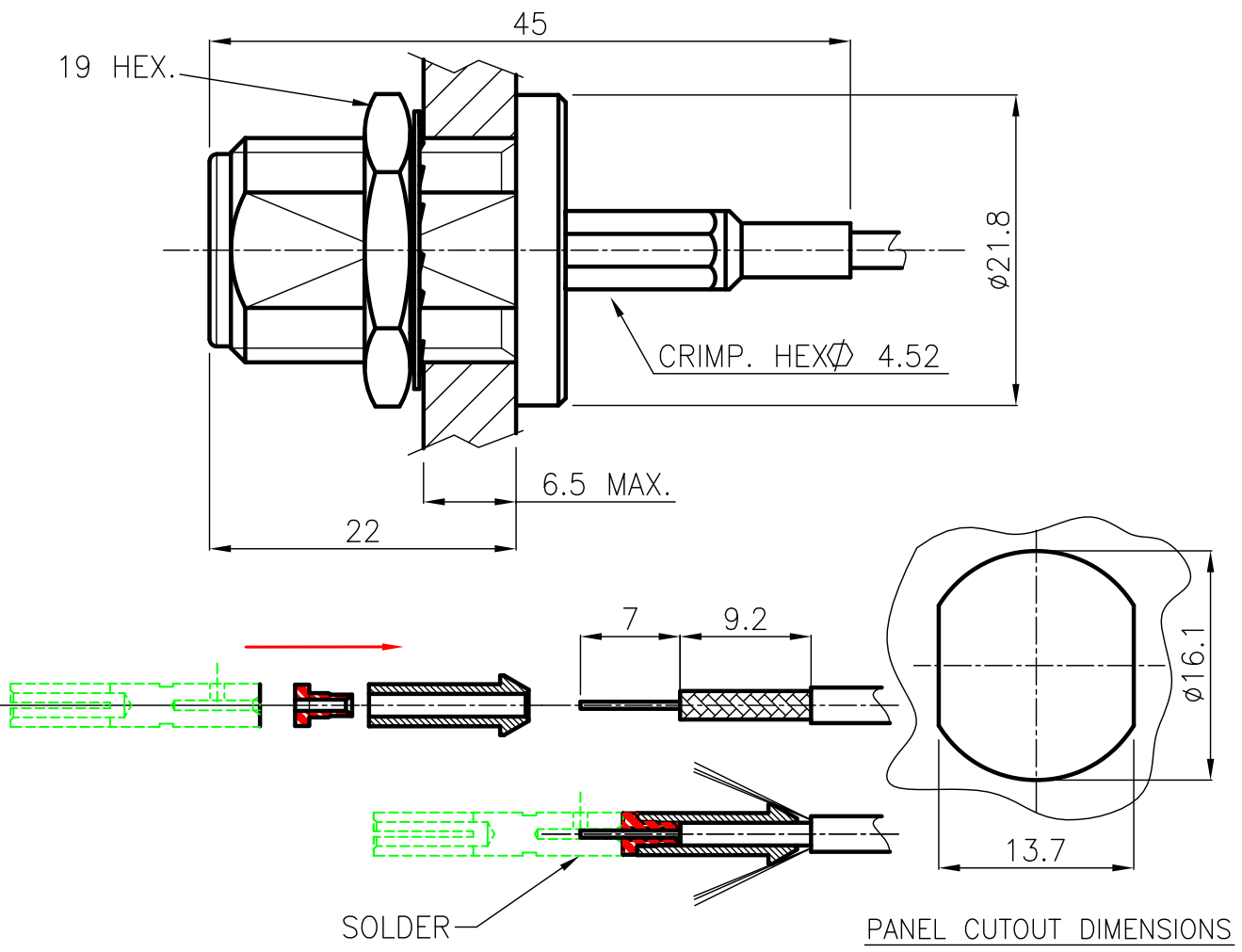

SPECIFICATIONS

Mating and dimensions as per CECC 22210

ELECTRICAL CHARACTERISTICS

RANGE	FREQUENCY	RETURN LOSS
DC ÷ 1	GHz	32 dB
1 ÷ 2.5	GHz	30 dB
2.5 ÷ 4	GHz	24 dB

MATERIALS AND FINISH

Body	Brass	White Bronze
Center contact	Beryllium copper	Au
Insulator	PTFE	
Other metal parts	Brass	Ni
Gasket	Silicon rubber	

FOR CABLES : RG 316/U-RG 174/U-RG 188A/U

MOD. 101 PROTOTIPI

DENOMINAZIONE		
50 Ohm - N SERIES CONNECTOR BULKHEAD		
STRAIGHT SOCKET SOLDER-CRIMP		
SCALA	2 : 1	CONTR.
DATA	08.05.02	DIS.
FILE	NPD5403C	APPROV. A.Q.

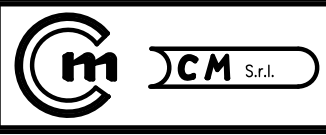

N° CODICE
NPD.54.003