

DIST.

A TERMINI DI LEGGE E' VIETATA LA RIPRODUZIONE O LA NOTIFICAZIONE DI QUESTO DISEGNO A TERZI SENZA AUTORIZZAZIONE

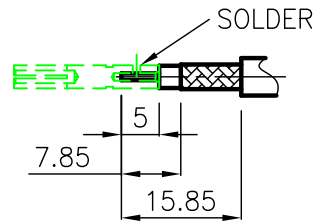
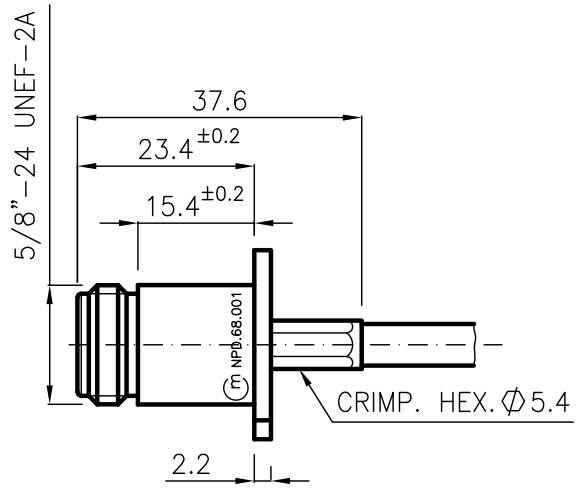
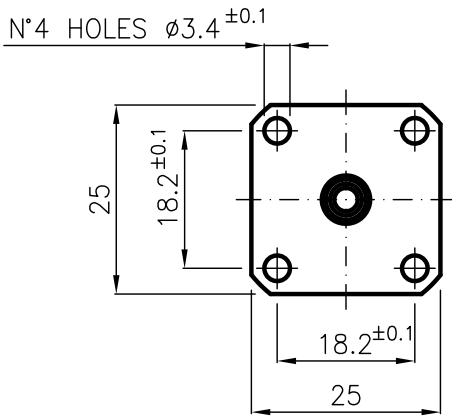

SPECIFICATIONS

Mating and dimensions as per CECC 22210

MATERIALS AND FINISH

Body	CW614N as per UNI EN 12164	White Bronze
Center contact	Beryllium copper	Au
Insulator	PTFE	
Crimping ferrules	Soft copper	Ni

FOR CABLE : RG 142 B/U - RG 223 /U

MOD. 101

			DENOMINAZIONE		
			50 Ohm - N SERIES CONNECTOR		
			BULKHEAD STRAIGHT SOCKET WITH CRIMP ATTACHMENT		
			SCALA 1 : 1	CONTR. Binelli	DATA 04.01.01
/	ISSUED	04.01.01	FILE NPD6801C	APPROV. A.Q.	DIS. Binelli
REV.	N° MOD.	DATA			



N° CODICE
NPD.68.001