

DIST.

A TERMINI DI LEGGE E' VIETATA LA RIPRODUZIONE O LA NOTIFICAZIONE DI QUESTO DISEGNO A TERZI SENZA AUTORIZZAZIONE

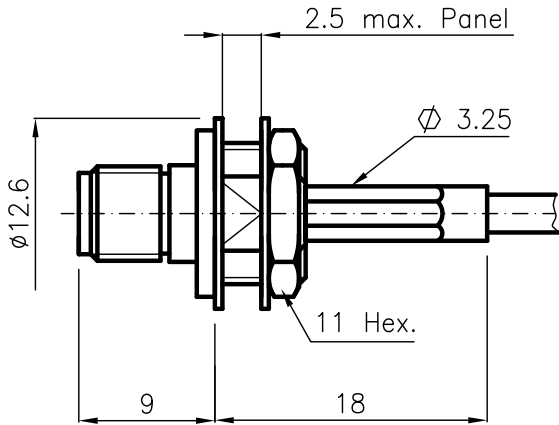

PANEL CUTOUT DIMENSION

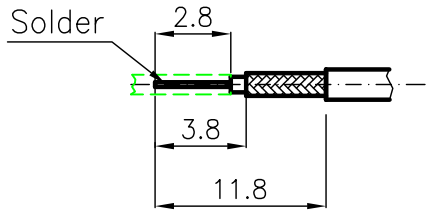
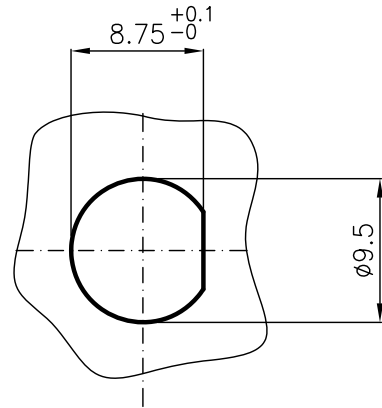

SPECIFICATIONS

Mating and dimensions as per CECC 22110

MATERIALS AND FINISH

P.N. SUFFIX	Body and locknut	Socket inner contact
002	Brass, Au	Beryllium copper Au
202	Stainless steel Passivated	Beryllium copper Au
302	Stainless steel Au	Beryllium copper Au
502	Brass, White Bronze	Beryllium copper Au

FOR CABLES : RG316/U

MOD. 101

			DENOMINAZIONE		
			50 Ohm - SMA SERIES COAXIAL CONNECTOR		
			BULKHEAD STRAIGHT SOCKET - SOLDER CRIMP		
SCALA		2:1	CONTR. CUCCHI I.		DATA 27.03.06
FILE		DPD65xx2C	APPROV. CUCCHI M.		DIS. Lorenzon I.
REV.	N° MOD.	DATA			
/	EMESSO	27.03.06			

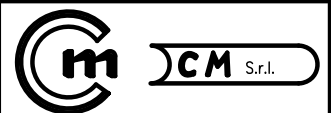

N° CODICE
DPD.65.XX2