

DIST.

A TERMINI DI LEGGE E' VIETATA LA RIPRODUZIONE O LA NOTIFICAZIONE DI QUESTO DISEGNO A TERZI SENZA AUTORIZZAZIONE

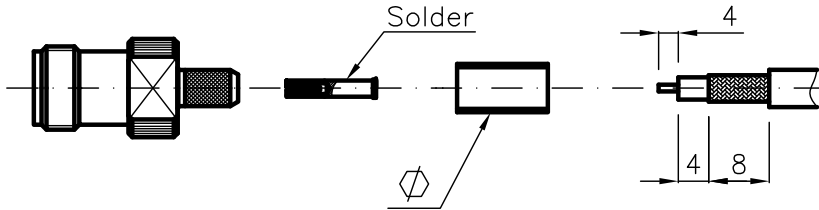
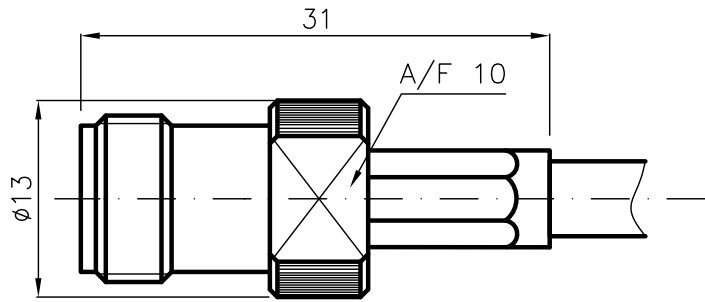

MATERIALS AND FINISH

Body	Brass	Ni 3 μ
Inner contact	Brass	Au 0.5 μ
Insulator	PTFE	
Crimping ferrules	Soft copper	Ni 3 μ

ELECTRICAL

Frequency range 0 ÷ 4 GHz
VSWR 1.3 Max

CODE	CABLE	L mm	CRIMP \varnothing FERRULE
HPD.54.001	RG 142B/U – RG 223/U	31	5.41
HPD.54.002	RG 58B/U	31	5.41
HPD.54.003	LMR-240	31	6.8
HPD.54.004	RG213/U – RG214/U – TYPE CX-214	SEE SINGLE DRAWING	

NOTE: STANDARD PACKING 10 PCS./BAG
Crimping tool code : CMC. 702/XX

			DENOMINAZIONE			
			50 Ohm – TNC SOCKET STRAIGHT SOLDER CRIMP			
			SCALA 2:1	CONTR. CUCCHI I.	DATA 21.06.04	
			FILE HPD540XC	APPROV. CUCCHI M.	DIS. ARONICA R.	
REV.	N° MOD.	DATA				N° CODICE
/	EMESSO	21.06.04				HPD.54.0XX

MOD. 101