

DIST.

A TERMINI DI LEGGE E' VIETATA LA RIPRODUZIONE O LA NOTIFICAZIONE DI QUESTO DISEGNO A TERZI SENZA AUTORIZZAZIONE

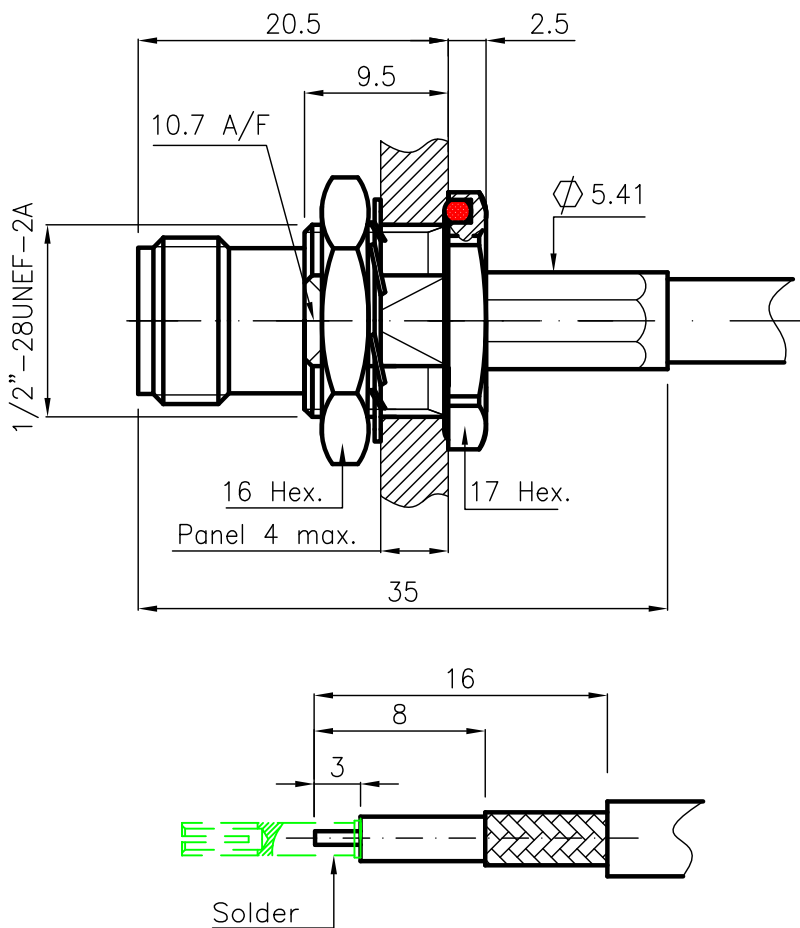

PANEL CUTOUT DIMENSIONS

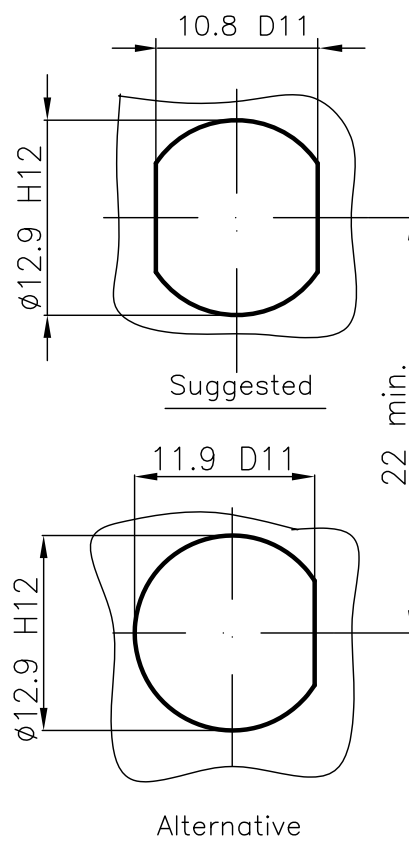

SPECIFICATIONS

Mating and dimensions as per CECC 22200

MATERIALS AND FINISH

Body and locknut	Brass	Ni 3 μ
Center contact	Beryllium Copper	Au 1 μ
Insulator	PTFE	
Shakeproof	Bronze	Ni 3 μ
Crimping ferrule	Soft Copper	Ni 3 μ
O-ring	Nitrile	

ELECTRICAL

FREQUENCY RANGE	VSWR
0 ÷ 3 GHz	≤ 1.10 (26 dB)

FOR CABLES : RG142-RG223

MOD. 101

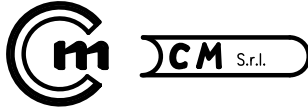
			DENOMINAZIONE						
			50 Ohm.-TNC SERIES CONNECTOR-BULKHEAD STRAIGHT SOCKET WITH CRIMP ATTACHMENT						
/		EMESSO	15.12.06	SCALA	2:1	CONTR. CUCCHI I.	DATA	15.12.06	N° CODICE
REV.	N° MOD.	DATA	FILE	HPD59003C	APPROV. CUCCHI M.	DIS. ARONICA R.			