

DIST.

A TERMINI DI LEGGE E' VIETATA LA RIPRODUZIONE O LA NOTIFICAZIONE DI QUESTO DISEGNO A TERZI SENZA AUTORIZZAZIONE

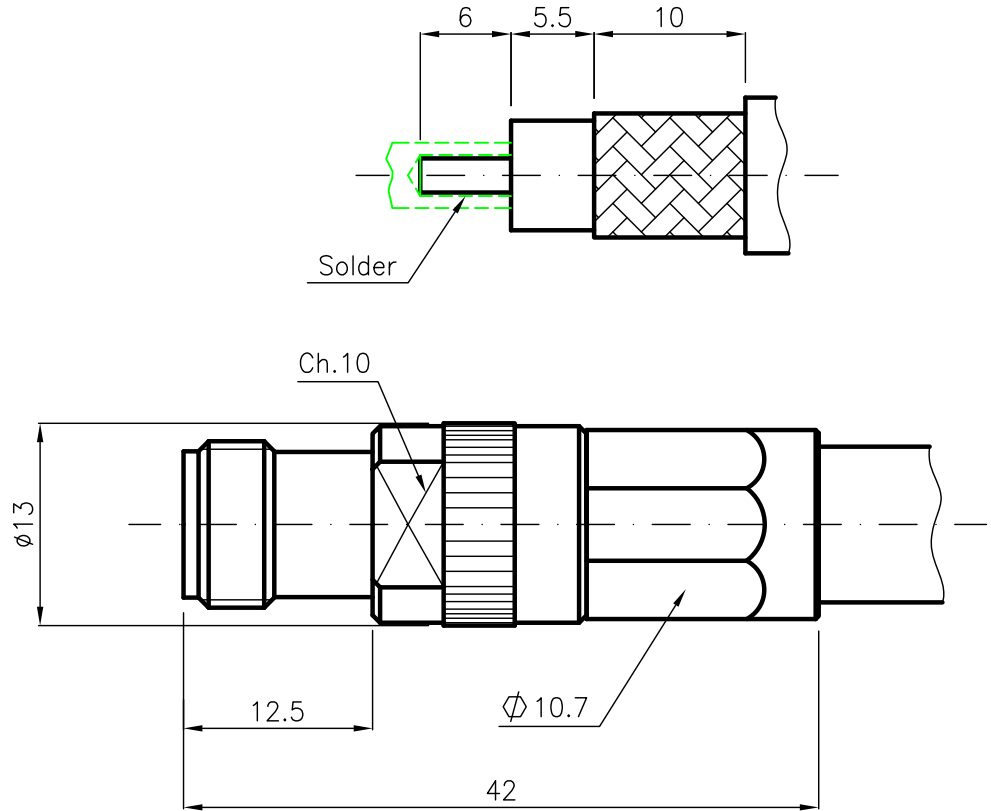

MATERIALS AND FINISH

Body	Brass	White Bronze
Locking nut	Brass	Ni
Center contact	Brass	Au
Insulator	PTFE	

ELETRICAL

Range frequency	WSWR
DC ÷ 1 GHz	≤ 1.06 (30 dB)

FOR CABLE : BELDEN 9292

MOD. 101

			DENOMINAZIONE				
			75 OHM - TNC STRAIGHT SOCKET - SOLDER CRIMP				
			SCALA 2:1	CONTR. CUCCHI I.	DATA 22.12.04		N° CODICE HPD.60.001
REV.	N° MOD.	DATA	FILE HPD60001C	APPROV. CUCCHI M.	DIS. ARONICA R.		