

DIST.

A TERMINI DI LEGGE E' VIETATA LA RIPRODUZIONE O LA NOTIFICAZIONE DI QUESTO DISEGNO A TERZI SENZA AUTORIZZAZIONE

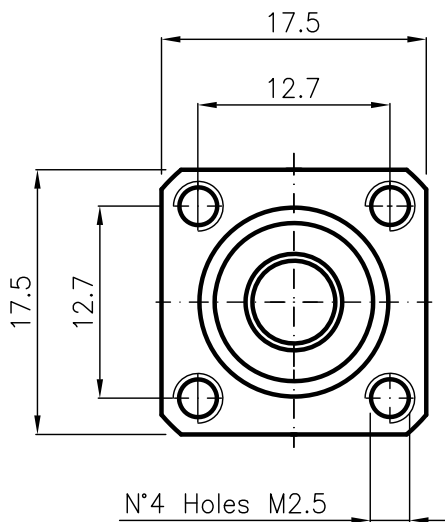

REAR PANEL - CUTOUT DIMENSIONS

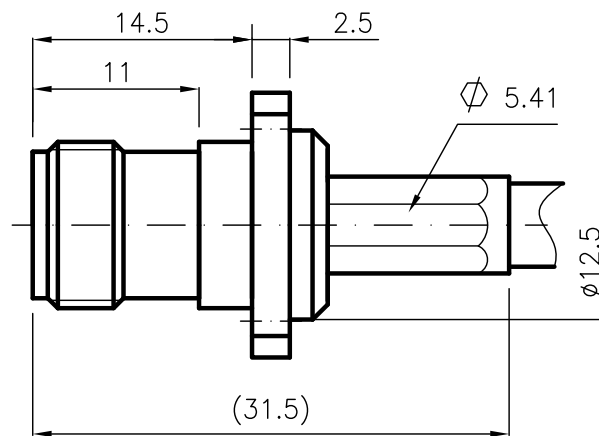
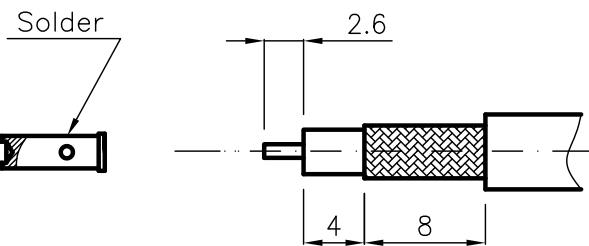

FRONT PANEL - CUTOUT DIMENSIONS

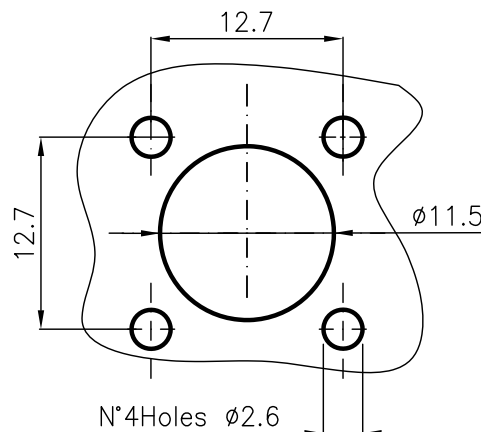
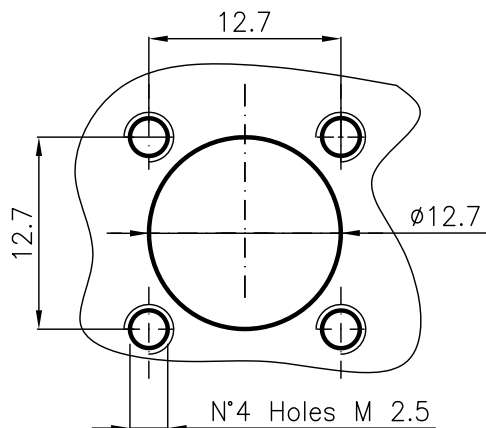

SPECIFICATIONS

Mating and dimensions as per CECC 22200

MATERIALS AND FINISH

Body	Brass	Ni 3μ
Inner contact	Beryllium copper	Au 1.27μ
Insulator	PTFE	
Crimp ferrule	Soft copper	Ni 3μ

FOR CABLES: RG 142/223

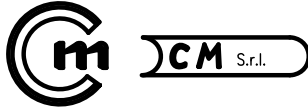
			DENOMINAZIONE			
			50 Ohm-TNC SERIES CONNECTOR BULKHEAD STRAIGHT SOCKET SOLDER CRIMP			
			SCALA 2:1	CONTR. CUCCHI I.	DATA 08.02.08	N° CODICE HPD.64.001
REV.	N° MOD.	DATA	FILE HPD64001C	APPROV. CUCCHI M.	DIS. ARONICA R.	

MOD. 101