

DIST.

A TERMINI DI LEGGE E' VIETATA LA RIPRODUZIONE O LA NOTIFICAZIONE DI QUESTO DISEGNO A TERZI SENZA AUTORIZZAZIONE

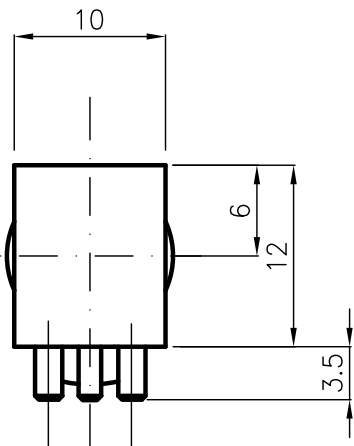
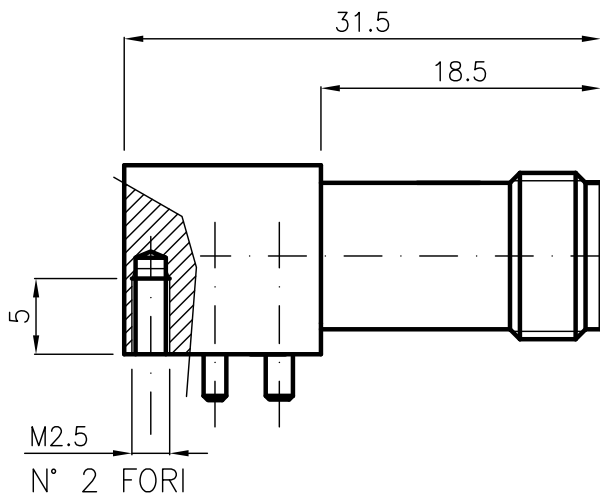
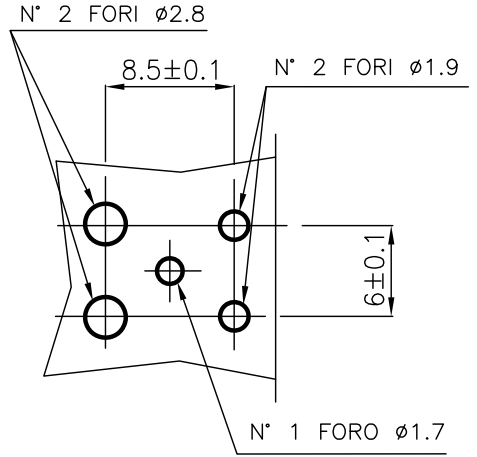
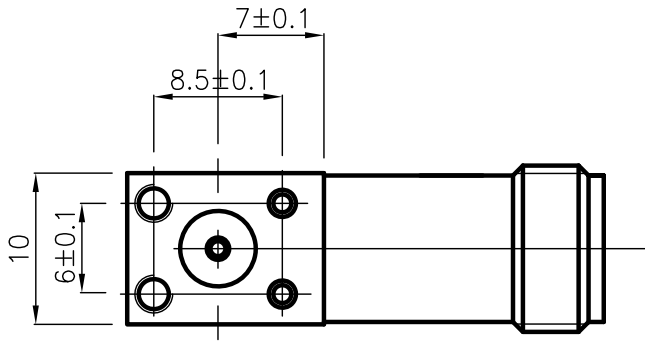

**DIMENSIONI DI ACCOPPIAMENTO**

**SECONDO CECC 22210**

**MATERIALI E FINITURE**

CORPO TNC PRESA  
 CORPO LATO C.S.  
 CONTATTO CENTRALE  
 ISOLANTE

OTTONE White Bronze  
 OTTONE White Bronze  
 CuBe Au  
 PTFE

**TRATTAMENTO GALVANICO IDONEO  
 A SUPERARE LA PROVA DI NEBBIA SALINA  
 SECONDO IEC 68-2-11 PROVA KA**

MOD. 101

			DENOMINAZIONE		
			TNC PRESA GOMITO DA C.S.		
SCALA		2:1	CONTR. CUCCHI I.		DATA 09.01.06
FILE		HPG03003C	APPROV. CUCCHI M.		DIS. Lorenzon I.
REV.	N° MOD.	DATA			
/	EMESSO	09.01.06			

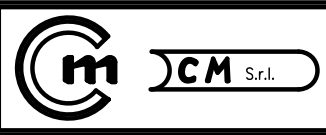

N° CODICE  
**HPG.03.003**