

DIST.

A TERMINI DI LEGGE E' VIETATA LA RIPRODUZIONE O LA NOTIFICAZIONE DI QUESTO DISEGNO A TERZI SENZA AUTORIZZAZIONE

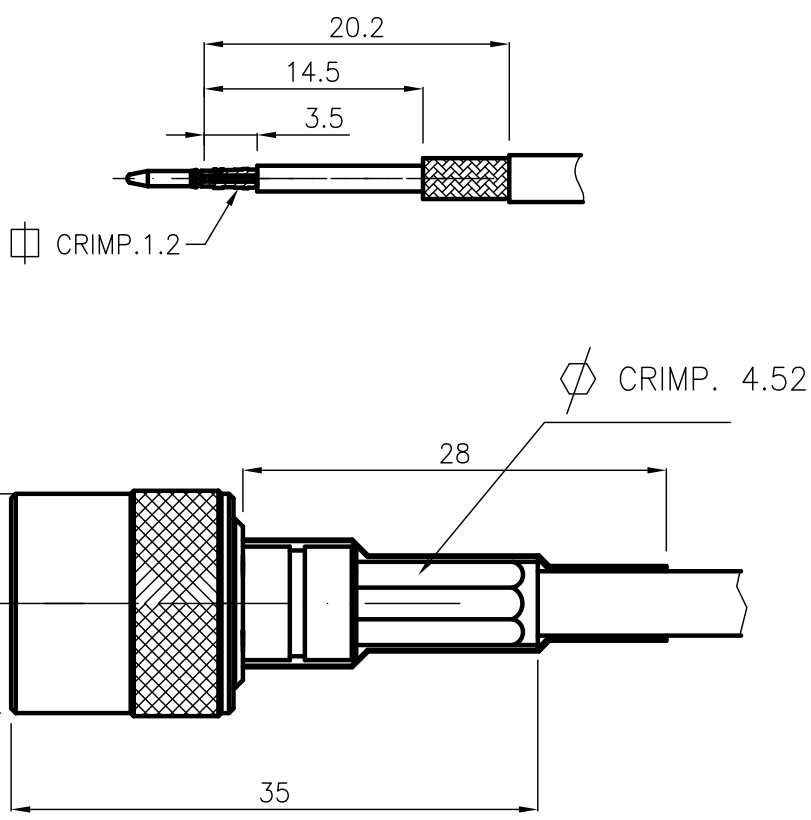

SPECIFICATIONS

Mating and dimensions as per CECC 22200

MATERIALS AND FINISH

Body	Brass	White Bronze
Inner contact	Brass	Au
Insulator	PTFE	
Crimping ferrule	Soft copper	Ni
Locking nut	Brass	Ni
Gasket	Silicone rubber	
Heatshrink tube adesive	Polyolefine	

CRIMPING TOOL: CMC.702/13

For cable: RG 59 Miniature

			DENOMINAZIONE		
			75 Ohm - SERIES CONNECTOR TNC STRAIGHT PLUG- FULL-CRIMP (IP65)		
SCALA		2:1	CONTR. CUCCHI I.		DATA
/ EMESSO		02.03.05	APPROV. CUCCHI M.		02.03.05
REV.	N° MOD.	DATA	FILE	HSD58001C	

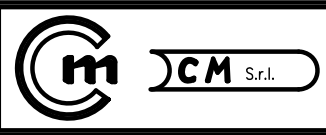

N° CODICE
HSD.58.001

MOD. 101